



iLOQ S5
Europrofile Lock Cylinder

iLOQ D5S.XXX(A).SB

iLOQ D5S.XXX(L).SB

User Guide

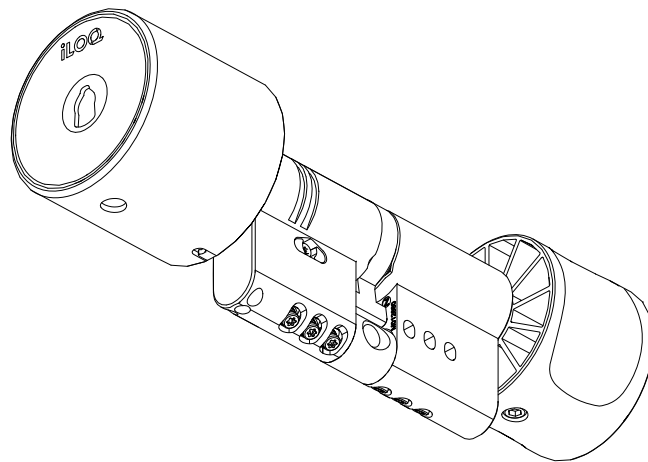

04/2024

Rev. 2.1

Document ID

300598

iLOQ Oy



support.ilq.com

1. Content

1.	Content	2
2.	Safety Information	3
2.1	Safety signs	3
3.	Overview	3
4.	Before installation	3
4.1	Mandatory precautions	3
4.2	General notes.....	4
4.3	Manufacturers involvement	5
5.	Installation	6
5.1	iLOQ D5S.1XX series	6
5.2	iLOQ D5S.2XX series	7
5.3	iLOQ D5S.3XX series	9
5.4	iLOQ D5S.4XX series	11
5.5	iLOQ D5S.7XX series	12
6.	Removing and installing the electronic knob	13
7.	Cylinder extensions.....	16
7.1	One side - Version 1	16
7.2	One side - Version 2 (5-15 mm)	19
7.3	One side - Version 2 (20 - 30 mm)	21
7.4	One side - Version 2 (35 - 70 mm)	24
7.5	Both sides.....	27
7.6	Long neck.....	27
8.	After installation	28
9.	Disposal of decommissioned products.....	29
10.	Compliance	30

2. Safety Information

2.1 Safety signs

Sign	Description
	<p>General notice sign. Indicates particularly important information about the installation or product.</p>
	<p>Read these instructions carefully before using products. This information is to ensure your safety and long lifetime of the products.</p>

3. Overview

iLOQ D5S Europrofile Lock Cylinders are battery-free digital lock cylinders for the iLOQ S5 locking system. The iLOQ D5S Lock Cylinders are powered with the energy from the motion of inserting the key into the lock cylinder. This eliminates the need for any type of batteries or cabling.

4. Before installation

4.1 Mandatory precautions

- These instructions and any maintenance instructions should be passed on by the installer to the user. If there are any deviations from the contents in foreign language versions of the documentation, the English original shall apply in case of doubt.
- iLOQ D5S cylinders must be installed and used carefully without excessive force.
- Make sure that the cylinder meets all local regulation and is suitable to be used with the door and lock.
- Do not modify the product in any way, except in accordance with the modifications described in these instructions.
- It is not allowed to uninstall or alter the anti-panic mechanism in any way. The functionality of the mechanism cannot be guaranteed if it has been tampered with.
- Only use the cylinders for the purpose of opening and locking doors, any other use is not permitted.
- The key is to be kept secure so that only an authorized person can use it.
- If a key is lost, blocklisting of the lost key shall be done with the iLOQ Manager software and affected locks shall be reprogrammed.

4.2 General notes

- The iLOQ cylinders are successfully tested according the EN 1634-1 (EUF129-19003368) for 120 minutes in a hinged single leaf steel door.
- Where the D5S cylinder is manufactured in more than one size, make sure that you select the correct size.
- Make sure that any seals or weather-stripping fitted to the complete door assembly, does not inhibit the correct operation of then D5S lock cylinder.
- Make sure that no projection of the D5S cylinder and associated parts can prevent the door from swinging freely.
- Fit all components necessary for the specific installation in order to ensure compliance with EN15684 standard.
- The cylinder must protrude less than 1 mm on outside of the door to ensure proper operation.
- Before fitting D5S cylinder to a fire/smoke resisting door, examine the fire certification to ensure conformity. Consult an iLOQ sales representative for the correct configuration.
- To extend the cylinder length, only use the associated D5 cylinder extensions (AD5.Exx).
- The incorrect type of cylinder can block or hinder the panic mechanism of the panic mortise locks. Make sure that the anti-panic cylinder (D5S.7xx) is installed. Do not use other cylinder types (D5S.1xx/2xx/3xxx etc.) unless you have made sure the lock type does not need a specific cam position and the cam cannot block the panic functionality. Confirm the information from the declaration of conformity provided by the mortise lock manufacturer.
- After installation, make sure that all parts of the lock are in an operational condition. When the D5S lock cylinder is used in combination with panic locks, make sure the panic function of the mortise lock is operational and cannot be hindered.
- The long neck versions have specially been developed for doors that do not have a Euro-profile cut out inside the door frame resp. escutcheon/cylinder ring but only has a round hole.
- Use as a spare part only the article "A5.001", and it is mandatory to mount the provided IP cover.
- Disposal of an RTC (Real Time Clock) into fire or a hot oven, or mechanically crushing or cutting of an RTC can result in an explosion.
- Leaving an RTC in an extremely high temperature surrounding environment can result in an explosion or the leakage of flammable liquid or gas.
- An RTC subjected to extremely low air pressure may result in an explosion or the leakage of flammable liquid or gas.
- To meet the Dutch SKG*** requirements use a D5S.XXXA.SB high security cylinder. Consult an iLOQ sales representative for correct configuration.
- Especially in industrial areas or near the sea, impurities can cause deposits in the form of rust and attacked the material. This equipment should be cleaned and maintained frequently.
- For security reasons, the cylinder will lock itself after 10-12 seconds. The key can then be removed. Turn the key back to the 12 o'clock position (either clockwise or anti-clockwise) and pull it out.
- After 5-10,000 usages, clean the contact rolls lightly with a lint-free cotton pad. Spray a small amount of high-quality lock oil i.e. CRC lock oil (with PTFE) onto the contact rolls.
- If the cylinder is not functioning properly, clean the cylinder with e.g. compressed air spray or similar.

4.3 Manufacturers involvement

No liability is accepted for damage to the doors or components due to incorrect installation. We reserve the right to make modifications or further technical developments without further notice.

5. Installation

5.1 iLOQ D5S.1XX series

1. Slide the lock cylinder into the lock case.

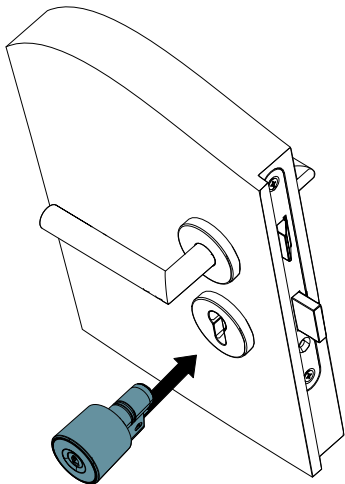

Make sure that the cam is pointing downwards.

2. Secure the cylinder to the lock case with an iLOQ fixing screw (A10.64, part of the delivery).
Use a tightening torque of 0.9 ... 1.1 Nm. If necessary, cut the screw to the correct length (calculation screw length: $L = \text{backset} + 10 \text{ mm}$).

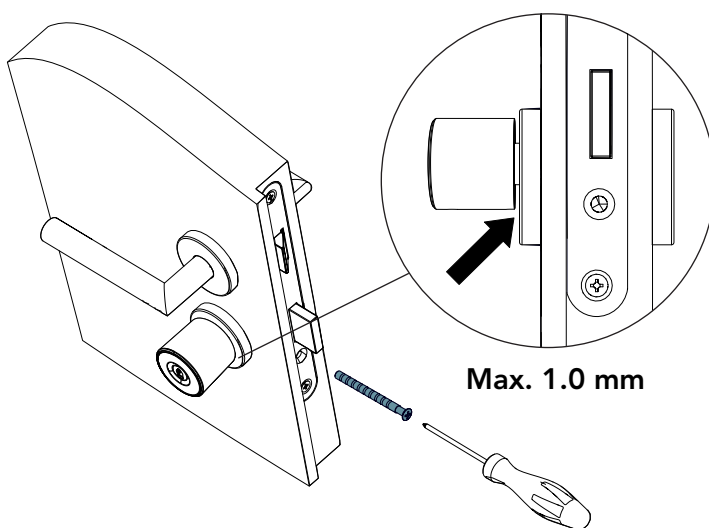

NOTE! Make sure that the cylinder frame is a maximum of 1.0 mm from the door leaf or escutcheon.

5.2 iLOQ D5S.2XX series

1. Detach the electronic knob from the lock cylinder as described in section "6. Removing and installing the electronic knob."
2. Slide lock cylinder into the lock case.
Make sure that the cam is pointing downwards.

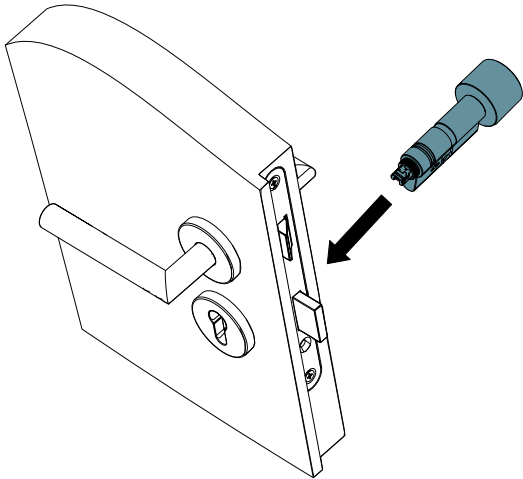

3. Secure the cylinder to the lock case with an iLOQ fixing screw (A10.64, part of the delivery).
Use a tightening torque of 0.9 ... 1.1 Nm. If necessary, cut the screw to the correct length (calculation screw length: $L = \text{backset} + 10 \text{ mm}$).

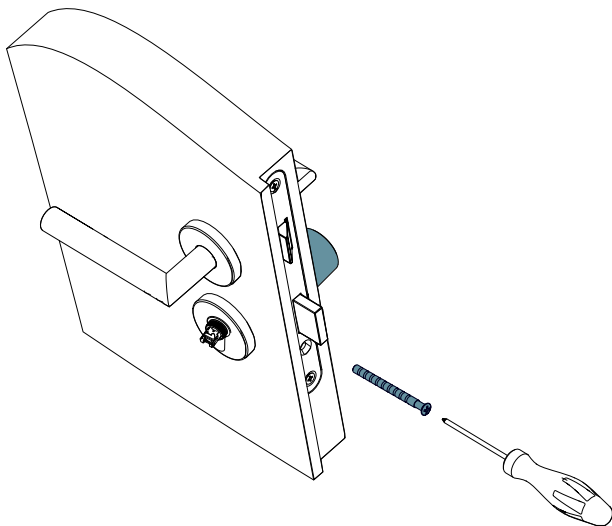

4. Install the electronic knob as described in chapter "6. Removing and installing the electric knob".

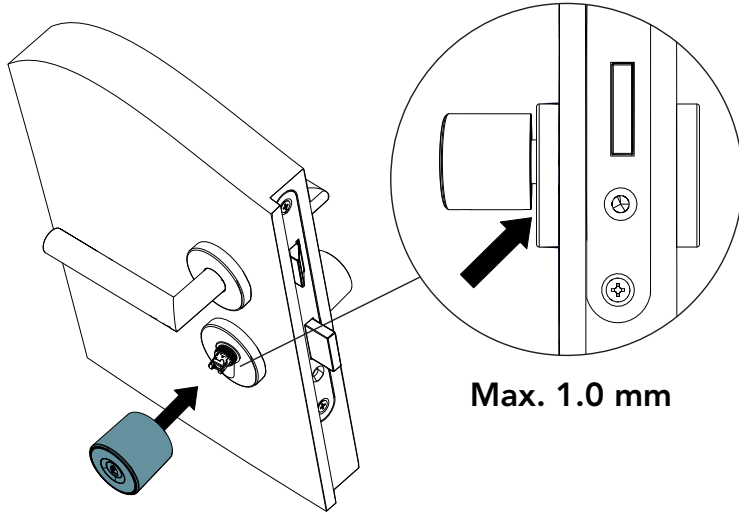

NOTE! Make sure that the cylinder frame is a maximum of 1.0 mm from the door leaf or escutcheon.

5.3 iLOQ D5S.3XX series

1. Slightly loosen the fixing screw of the turn knob with a 2 mm Allen key (counter-clockwise).
Loosen the fixing screw just enough to be able to remove the knob, do not remove it completely.

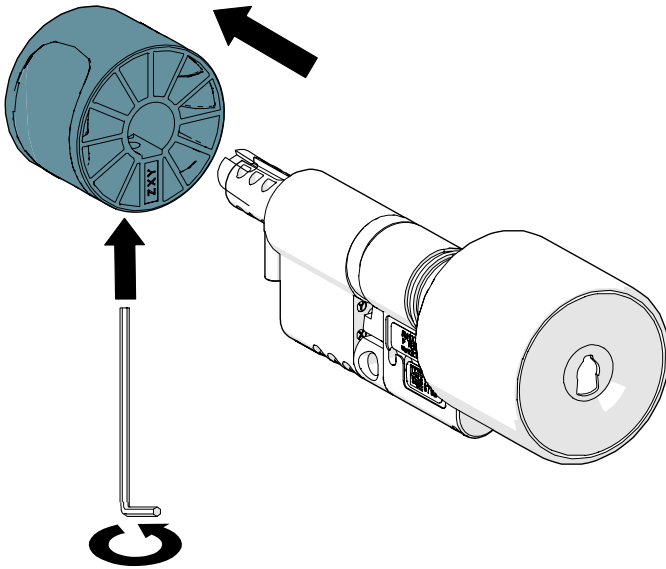

2. Slide the lock cylinder into the lock case.
Make sure that the cam is pointing downwards.

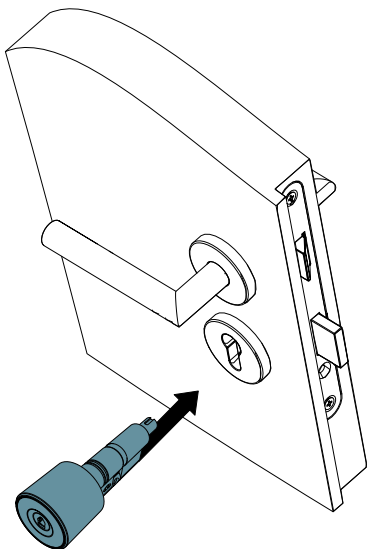

3. Secure the cylinder to the lock case with an iLOQ fixing screw (A10.64, part of the delivery).
Use a tightening torque of 0.9...1.1 Nm. If necessary, cut the screw to the correct length (calculation screw length: $L = \text{backset} + 10 \text{ mm}$).

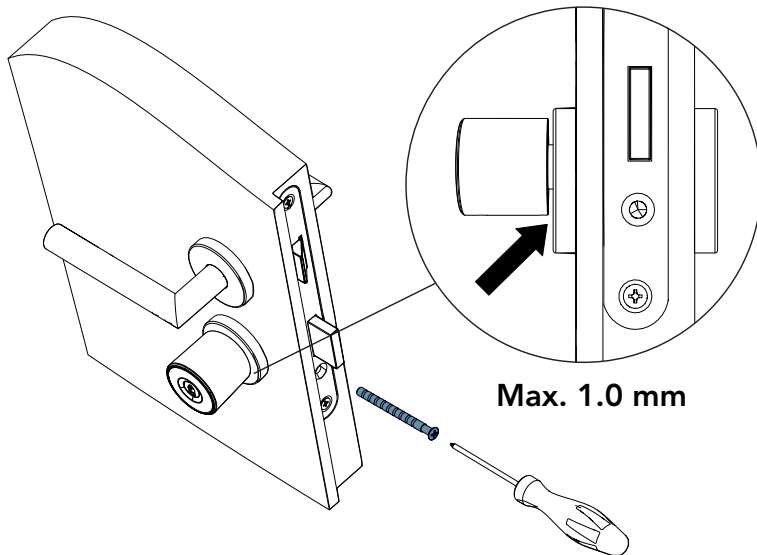

NOTE! Make sure that the cylinder frame is a maximum of 1.0 mm from the door leaf or escutcheon.

4. Insert the turn knob into place and tighten the fixing screw (clockwise).
Use a tightening torque of 1.5 Nm.

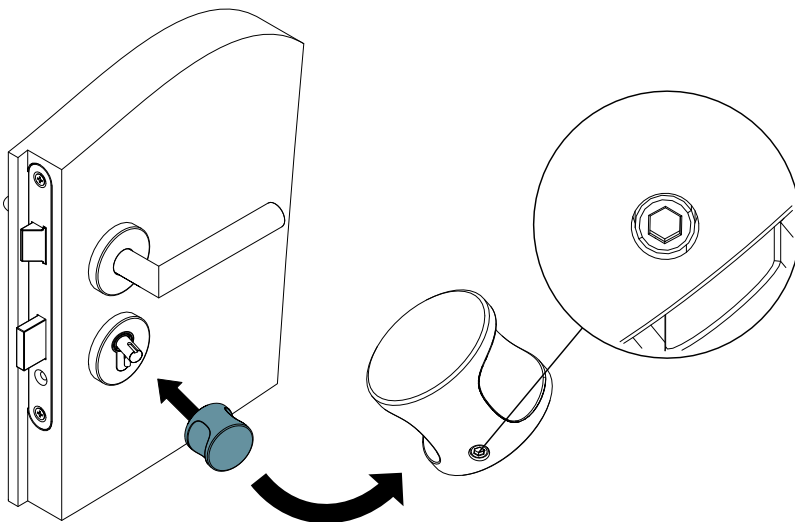

5.4 iLOQ D5S.4XX series

1. Slide the lock cylinder into the lock case.
Make sure that the cam is pointing downwards.

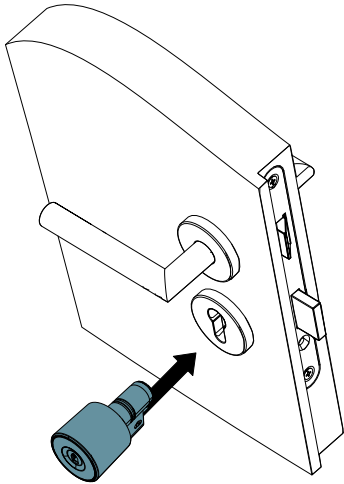

2. Secure the cylinder to the lock case with an iLOQ fixing screw (A10.64, part of the delivery).
Use a tightening torque of 0.9...1.1 Nm. If necessary, cut the screw to the correct length (calculation screw length: $L = \text{backset} + 10 \text{ mm}$).

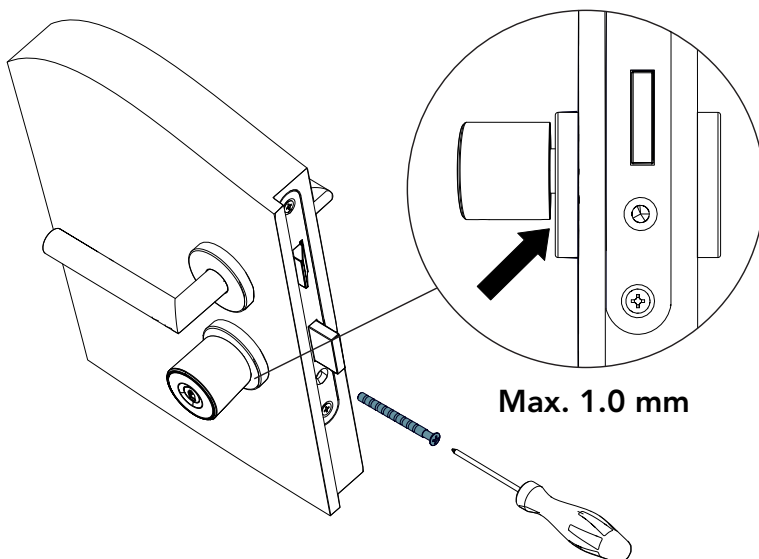

NOTE! Make sure that the cylinder frame is a maximum of 1.0 mm from the door leaf or escutcheon.

5.5 iLOQ D5S.7XX series

1. Slide the lock cylinder into the lock case.
Make sure that the cam is pointing downwards.

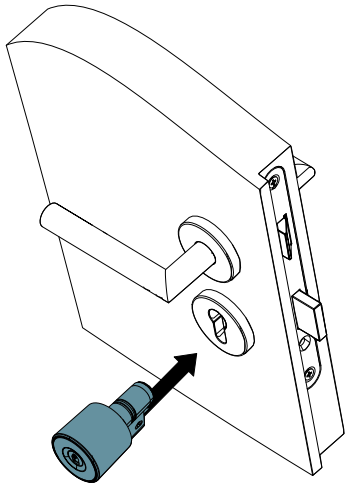

2. Secure the cylinder to the lock case with an iLOQ fixing screw (A10.64, part of the delivery).
Use a tightening torque of 0.9...1.1 Nm. If necessary, cut the screw to the correct length (calculation screw length: $L = \text{backset} + 10 \text{ mm}$).

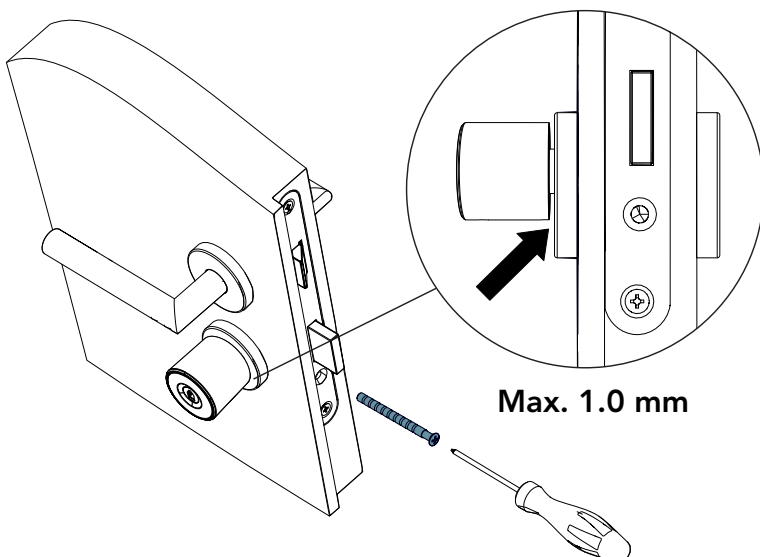

NOTE! Make sure that the cylinder frame is a maximum of 1.0 mm from the door leaf or escutcheon.



NOTE! According to standards EN179/EN1125 it is recommended to regularly verify the correct and faultlessly functionality of a panic door.

6. Removing and installing the electronic knob

In some installation locations it is necessary to remove the electronic knob from the lock cylinder. Follow these instructions to remove the knob. Re-install the electronic knob in the opposite order.

Be careful when inserting the knob not to break the connections on the cylinder. The removal of the knob is only possible for people who have access rights to the cylinder.

1. Insert a key with the appropriate access rights into the lock cylinder and turn the key approx. 45 degrees clockwise.
After turning the key, the blocker hatch will open automatically at the bottom of the outside knob. The hatch protects the fixing screw from unauthorized access.

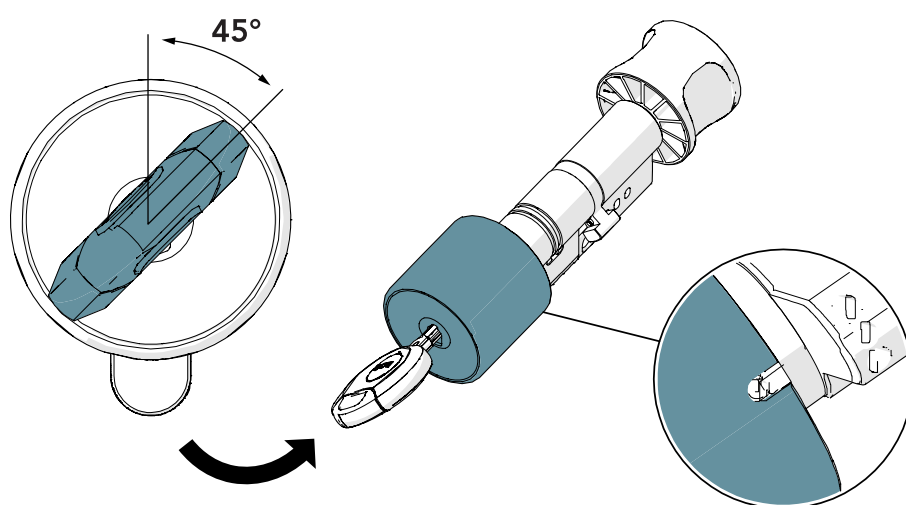

2. Use a Torx T6 tool to loosen the fixing screw by rotating it clockwise (left-hand thread). Do not remove the fixing screw completely, only loosen it just enough to be able to remove the knob.

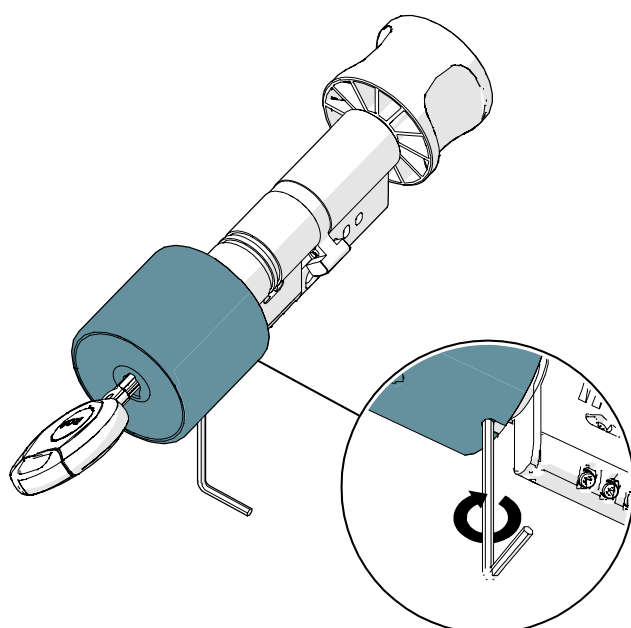

3. Remove the cover cup.

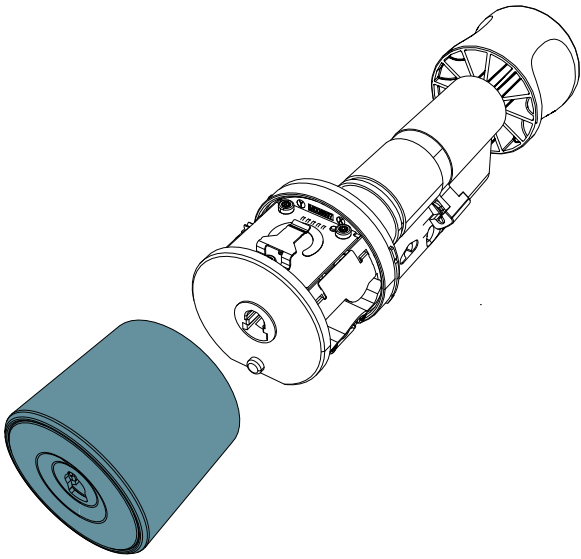

4. Remove the side screw counterclockwise with a Torx T6 tool and carefully detach the knob with the PCB.

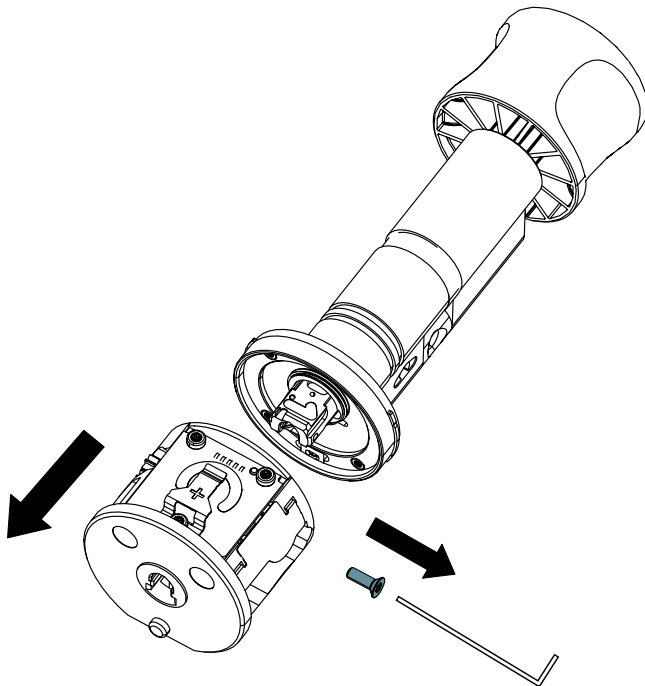

5. Loosen the back-plate screw with a Torx T6 tool.
Do not remove the screw completely, only loosen it just enough to be able to turn the back plate.

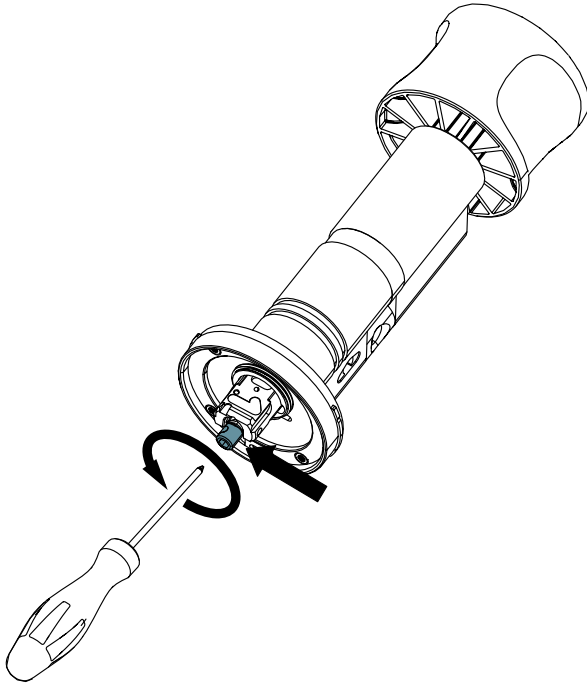

6. Rotate the backplate counterclockwise and pull it off.

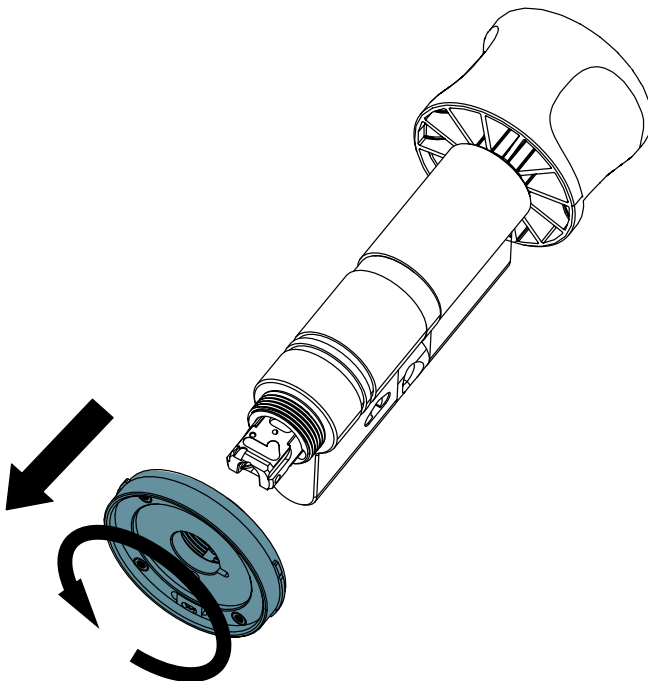

7. Cylinder extensions

The cylinder length is easily adjustable in 5 mm increments from 30 mm (basic length) to 100 mm with the extension piece system.

One extension piece can be added to both sides of the cam for the following cylinders:

- D5S.2xx > Double cylinder
- D5S.3xx > Knob cylinder
- D5S.4xx > Cylinder with dummy inside

The iLOQ D5S.1xx can only be extended on the knob side.

The iLOQ D5S.7xx.SD anti-panic cylinders are only provided in a set length due to safety reasons. The length cannot be adjusted.



NOTE! It is not possible to chain multiple extension pieces. Only one extension piece on each side can be installed.

7.1 One side - Version 1

1. Remove the three body fixing screws with a Torx T6 tool and set the screws aside for later use.

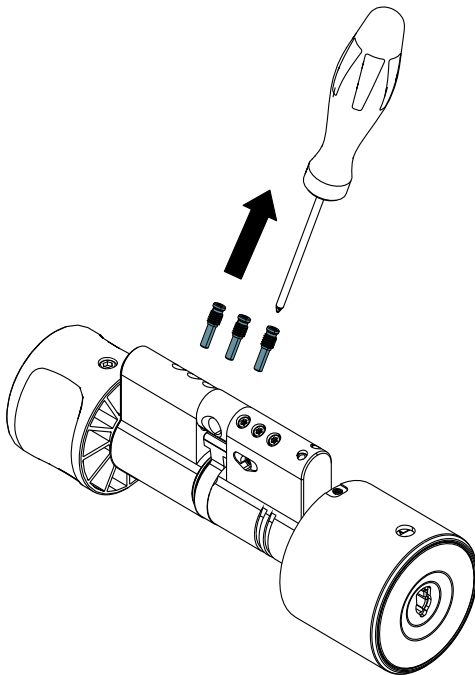

2. Pull the lock cylinder modules apart.

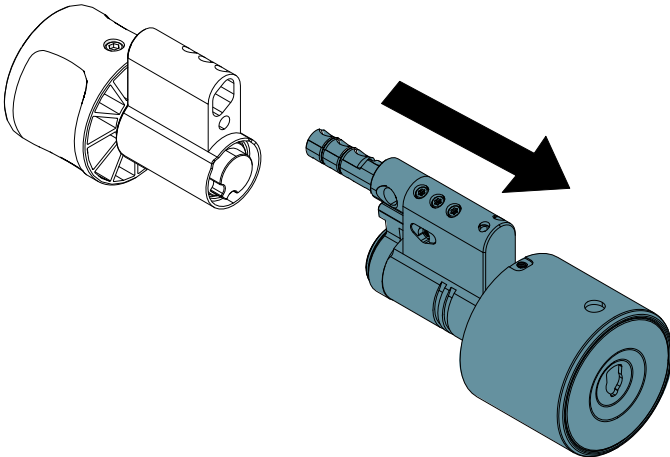

3. Slide the shaft into the lock unit and make sure that the seal is in the correct place. Secure the extension assembly with the provided screw. Use a Torx T10 tool (tightening torque 2.5 Nm). Make sure that the black O-ring is between the extension assembly and the lock unit. Make sure that the housing is aligned correctly.

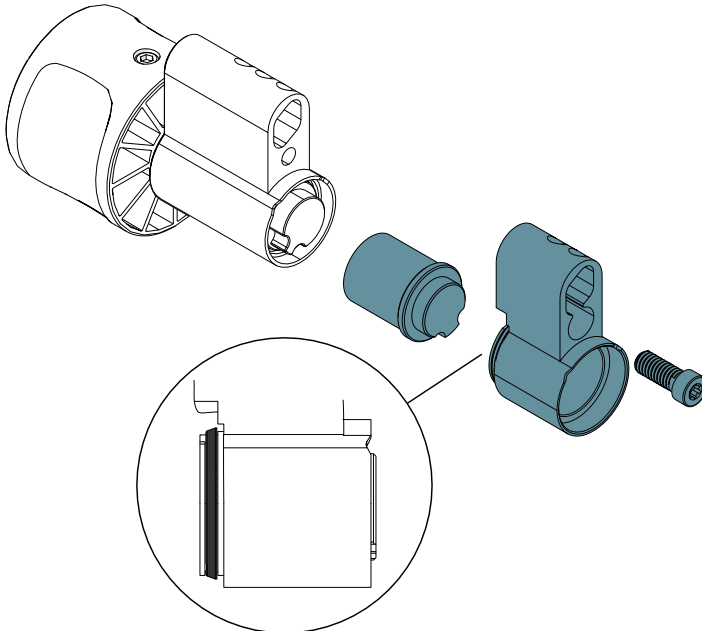

NOTE! Make sure that the O-ring is not damaged. If needed, replace with a new one (spare part kit available "A5.005").



NOTE! Make sure that the assembly (cylinder housings) is aligned straight.



NOTE! Make sure that the assembly of the cylinder extension is done in a dry environment.

4. Secure the extension assembly with the provided screw.
Use a Torx T10 tool (tightening torque 2.5 Nm).

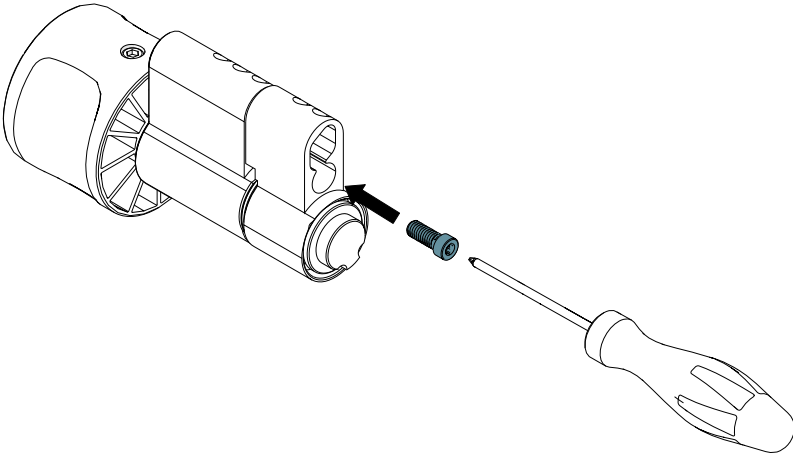

5. Slide the assembly with the backbone into the assembly with the extension piece and align the housings.

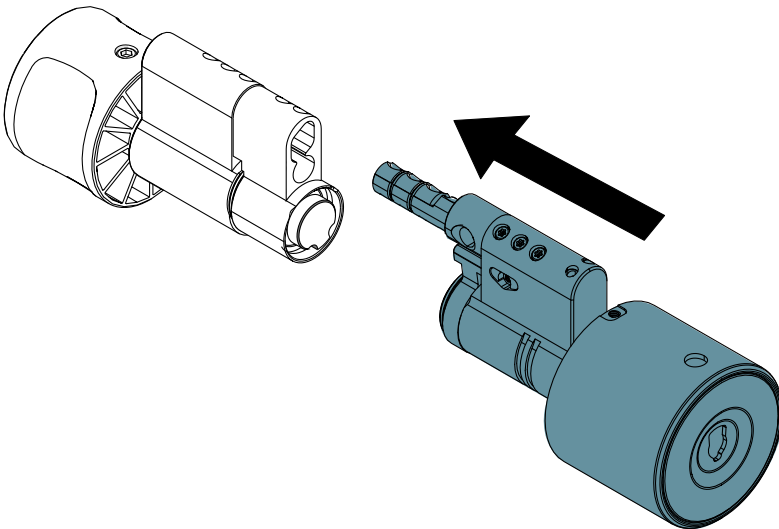

6. Secure the lock unit with the three body fixing screws set aside earlier.
Use a tightening torque of 0.55 ... 0.65 Nm.

7.2 One side - Version 2 (5-15 mm)

1. Remove the three body fixing screws with a Torx T6 tool and set the screws aside for later use.

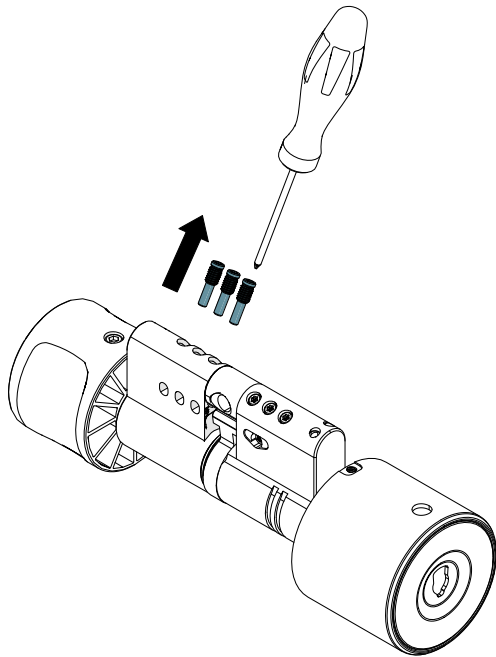

2. Pull the lock unit modules apart.

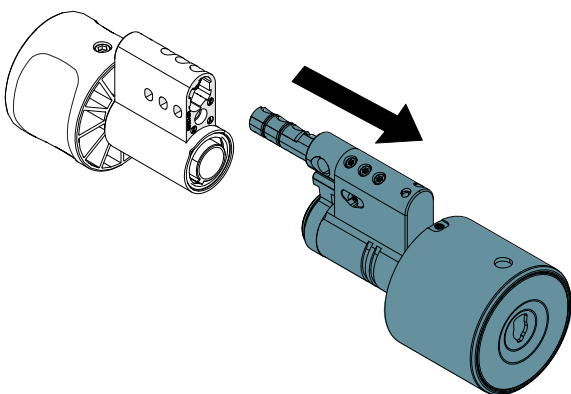

- Slide the shaft into the lock unit and make sure that the seal is in the correct place. Secure the extension assembly with the provided screw. Use a Torx T10 tool (tightening torque 2.5 Nm).

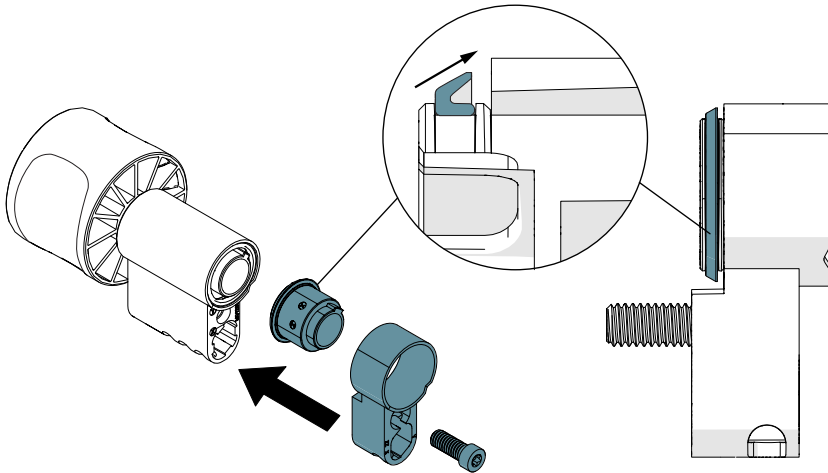

NOTE! Make sure that the conical seal is in place before assembly.



NOTE! Make sure that the assembly (cylinder housings) is aligned straight.



NOTE! Make sure that the assembly of the cylinder extension is done in a dry environment.

- Slide the assembly with the backbone into the assembly with the extension piece and align the housings.

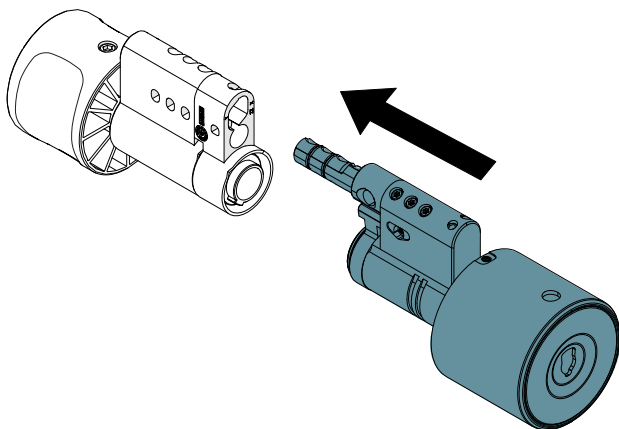

- Secure the lock unit with the three body fixing screws set aside earlier. Use a tightening torque of 0.55 ... 0.65 Nm.

7.3 One side - Version 2 (20 - 30 mm)

1. Remove the three body fixing screws with a Torx T6 tool and set the screws aside.

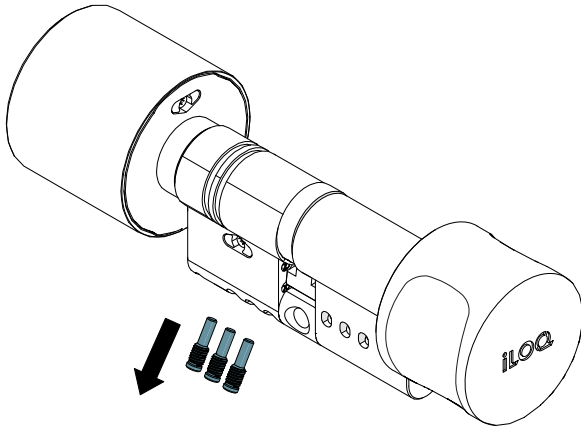

2. Pull the lock unit modules apart.

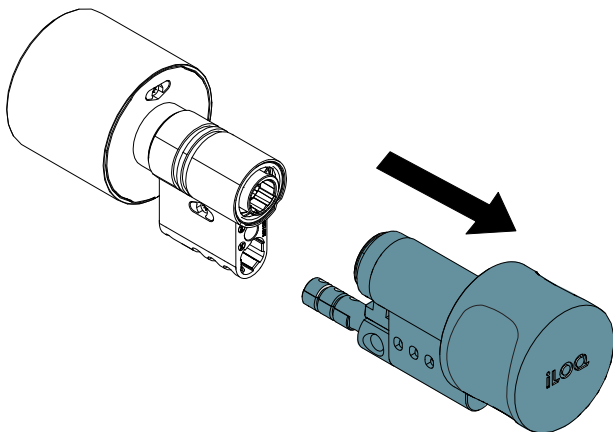

- Put the shaft into lock unit and check that the seal is in the correct place. Secure the extension assembly with the provided screw. Use a Torx T10 tool (tightening torque 2.5 Nm).

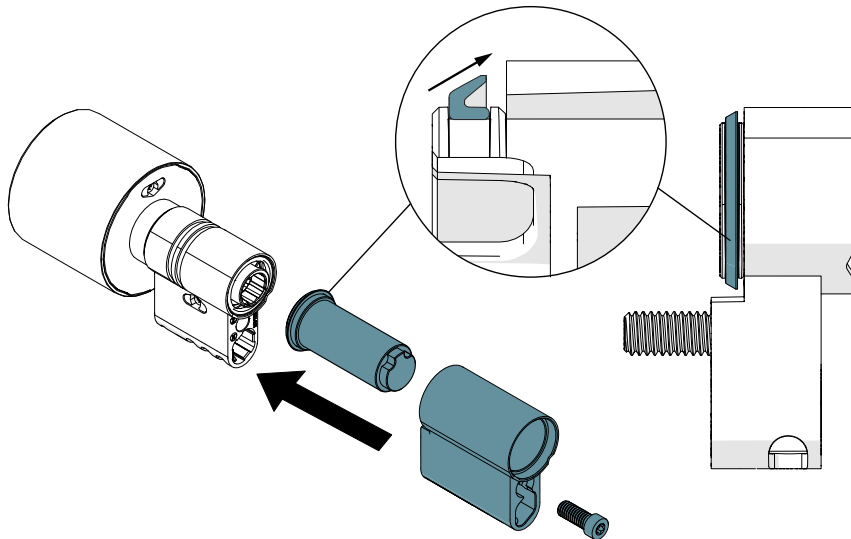

NOTE! Make sure that the conical seal is in place before assembly.



NOTE! Make sure that the assembly (cylinder housings) is aligned straight.



NOTE! Make sure that the assembly of the cylinder extension is done in a dry environment.

- Stretch the two O-rings carefully by using a tweezer, and pull out the (marked) metal piece horizontally (without damaging the O-rings).
Dispose of the removed part in accordance with local rules and regulations.

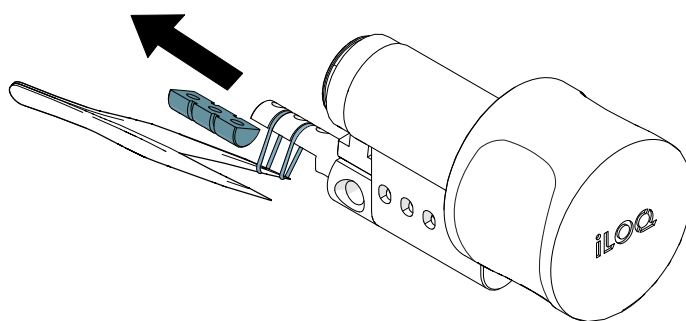

5. Install the extension to the back bone. The O-rings will secure the assembly.

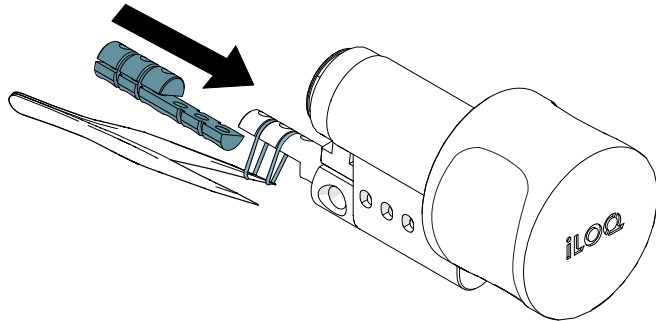

6. Slide the assembly with the backbone into the assembly with the extension piece and align the housings.

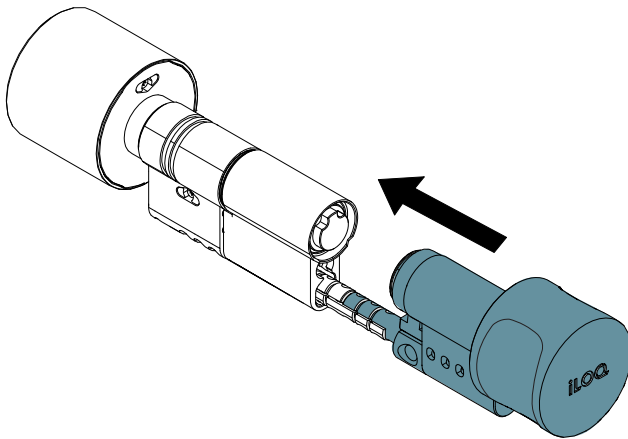

7. Secure the lock unit with the body fixing screws. Use a tightening torque of 0.55 ... 0.65 Nm.

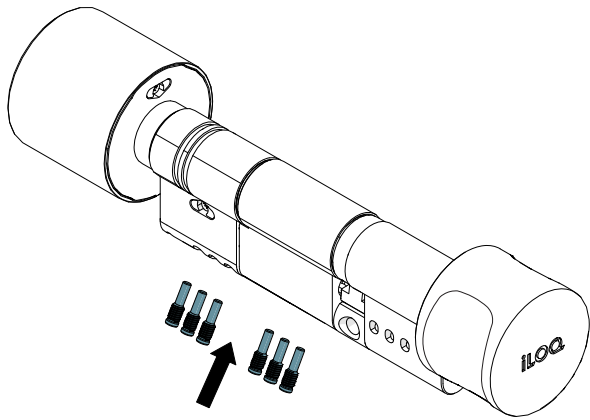

7.4 One side - Version 2 (35 - 70 mm)

1. Remove the three body fixing screws with a Torx T6 tool and set the screws aside for later use.

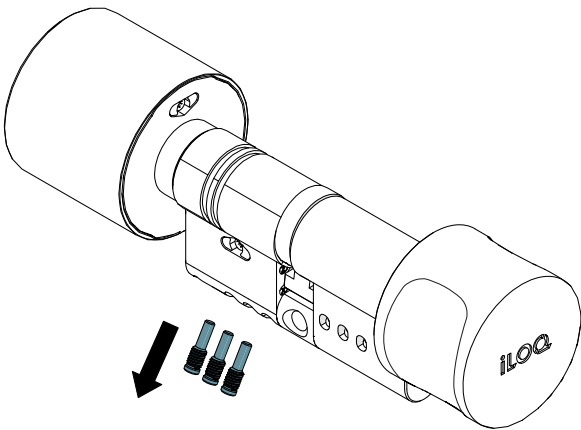

2. Pull the lock unit modules apart.

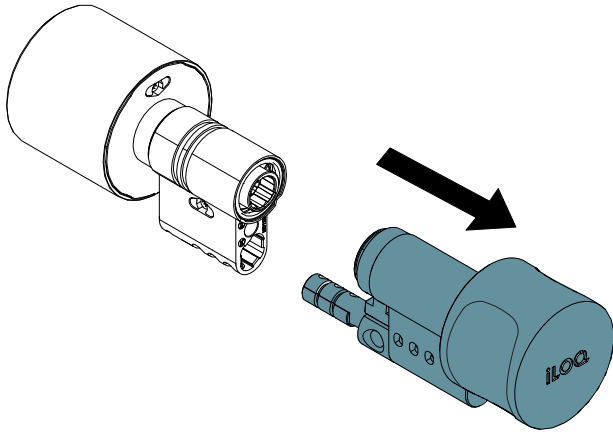

3. Put the shaft into lock unit and check that the seal is in the correct place. Secure the extension assembly with the provided screw.
Use a Torx T10 tool (tightening torque 2.5 Nm).

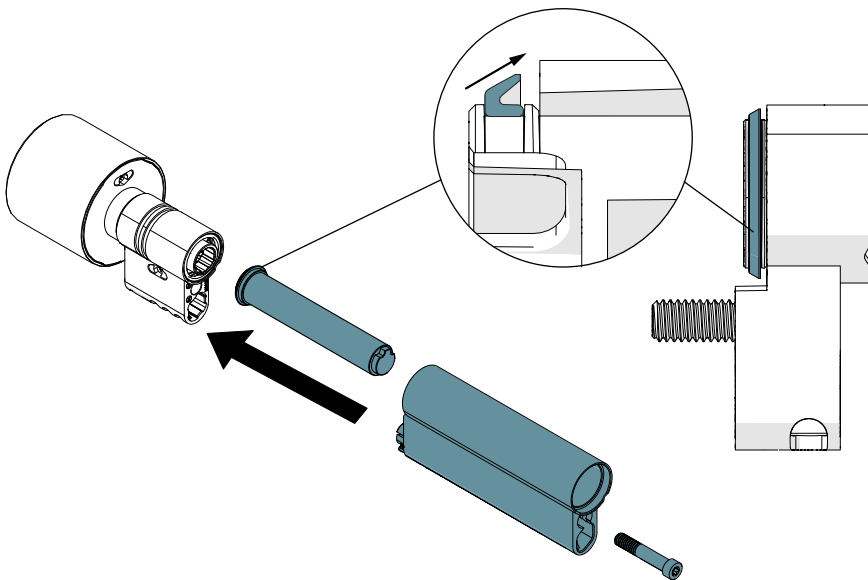

NOTE! Make sure that the conical seal is in place before assembly.



NOTE! Make sure that the assembly (cylinder housings) is aligned straight.



NOTE! Make sure that the assembly of the cylinder extension is done in a dry environment.

4. Secure the lock unit with the two provided screws.
Use a tightening torque of 0.55 ... 0.65 Nm.

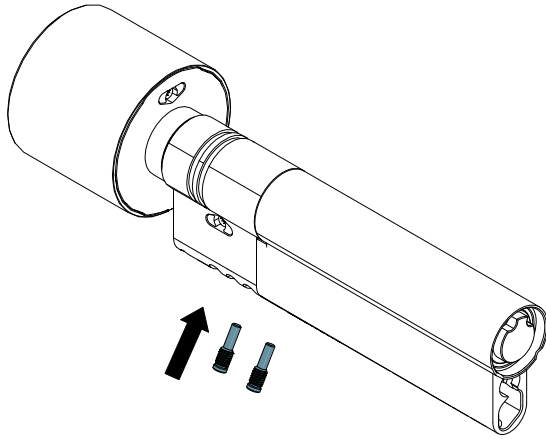

5. Slide the assembly with the backbone into the assembly with the extension piece and align the housings.

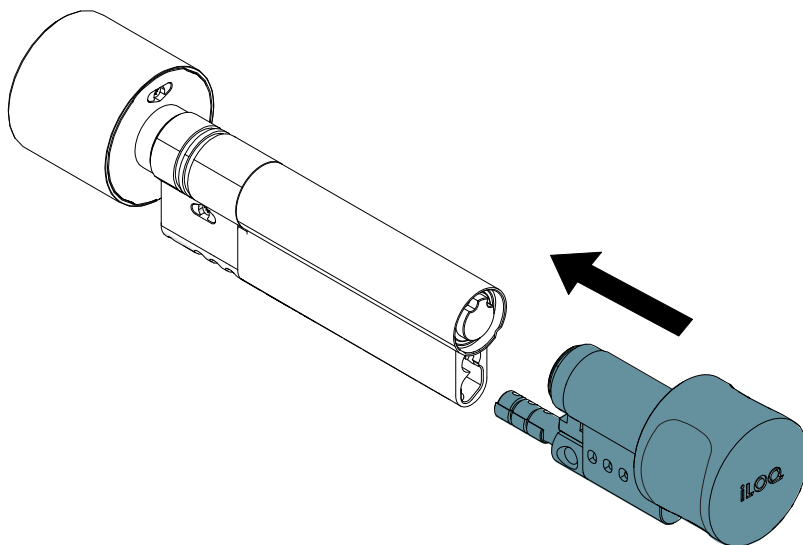

6. Secure the lock unit with the three fixing screws set aside earlier.
Use a tightening torque of 0.55 ... 0.65 Nm.

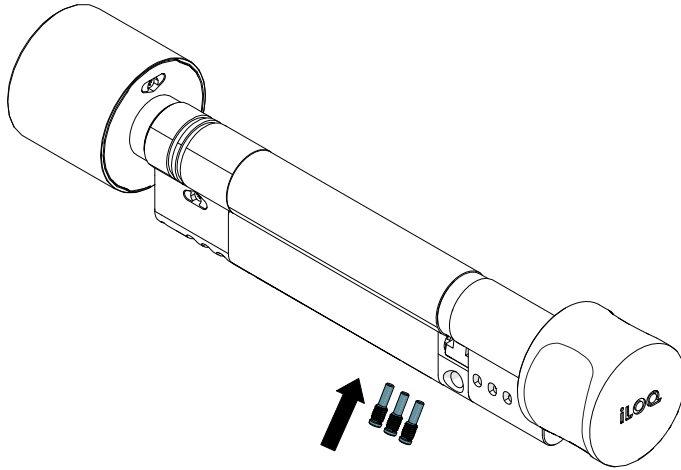

7.5 Both sides

The same concept and instructions apply as do for the one-side extension. See section "One side" for more information.

7.6 Long neck

If the outside housing of the long-neck version of the backbone needs to be extended, only two screws can be used to secure the backbone (see the following image).

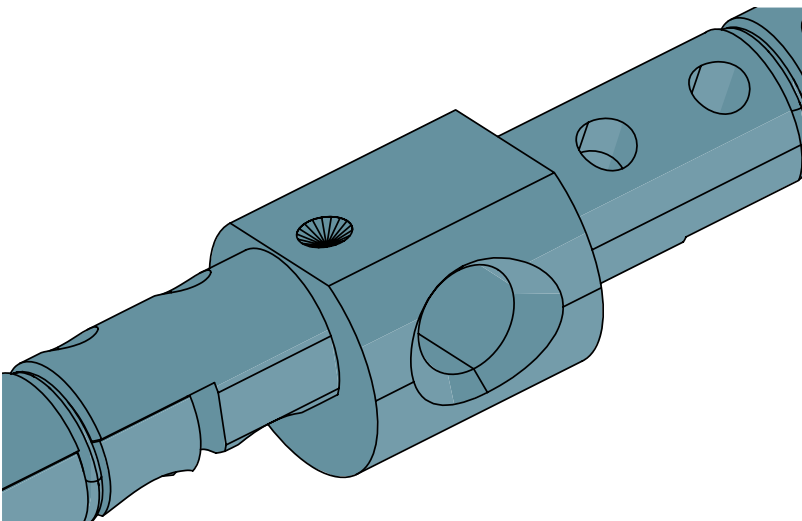

If the long-neck version is used in a door with the complete DIN cut-out, to improve the pulling protection safety of the cylinder, change the long-neck backbone to the DIN backbone (A5.009). The long neck backbone is slightly shorter than the DIN backbone. Or, it is also possible to rotate the existing backbone (outside to inside).

8. After installation

After installation, test the cylinder functionality to make sure that it does not prevent the lock case from working properly.





NOTE! When used in combination with panic locks it is especially important to make sure that all parts of the lock are operational and that the panic function of the mortise lock is guaranteed.





If you have any problems with the functionality, make sure that:

- the locking cylinder is not damaged.
- there are no foreign particles present in the keyway.
- the lock cylinder has been installed correctly.
- the mortise lock is not defective.
- the locking plates have been installed correctly.
- the door is not warped etc.

9. Disposal of decommissioned products

	<p>Never discard an electrical appliance in household waste. Follow the local laws and regulations for safe and environmentally friendly product disposal.</p>
	<p>Before discarding products, bear in mind that most iLOQ products are reusable. All programmable products can be reset to factory settings, after which they can be reused in another system.</p>

Recycling instructions of decommissioned products are depicted below.

Decommissioned product	Sorting
<p>Decommissioned iLOQ fittings, mounting accessories and thumb turn knobs can be recycled as scrap metal.</p>	
<p>Decommissioned iLOQ products containing electronics and circuit boards, such as iLOQ Lock Cylinders, keys, net bridges, door modules, key and RFID readers, and relay cards, must be recycled at an electrical and electronic equipment collection point.</p>	
<p>iLOQ products containing batteries and accumulators, such as key fobs, programming keys and clock circuits, should be recycled at a regional collection point for batteries and small accumulators.</p>	
<p>Most iLOQ packaging materials are suitable for cardboard and plastic recycling.</p>	

10. Compliance

The products mentioned inside this user guide are in conformity with the requirements of the directives declared on this page.

CE

SIMPLIFIED EU DECLARATION OF CONFORMITY:

Hereby, iLOQ Oy declares that the radio equipment type D5S Lock Cylinders are in compliance with Directive 2014/30/EU. The full text of the EU declaration of conformity is available at the following internet address: <https://www.iloq.com/en/declaration-of-compliance/>



iLOQ S5
Europrofile Lock Cylinder

iLOQ D5S.XXX(A).SB

iLOQ D5S.XXX(L).SB

User Guide

iLOQ

www.support.iloq.com

Elektroniikkatie 10

90590 Oulu

Finland